

INSTRUCTION MANUAL ÅSSA LUBRICATORS TYPE FL & TYPE FE

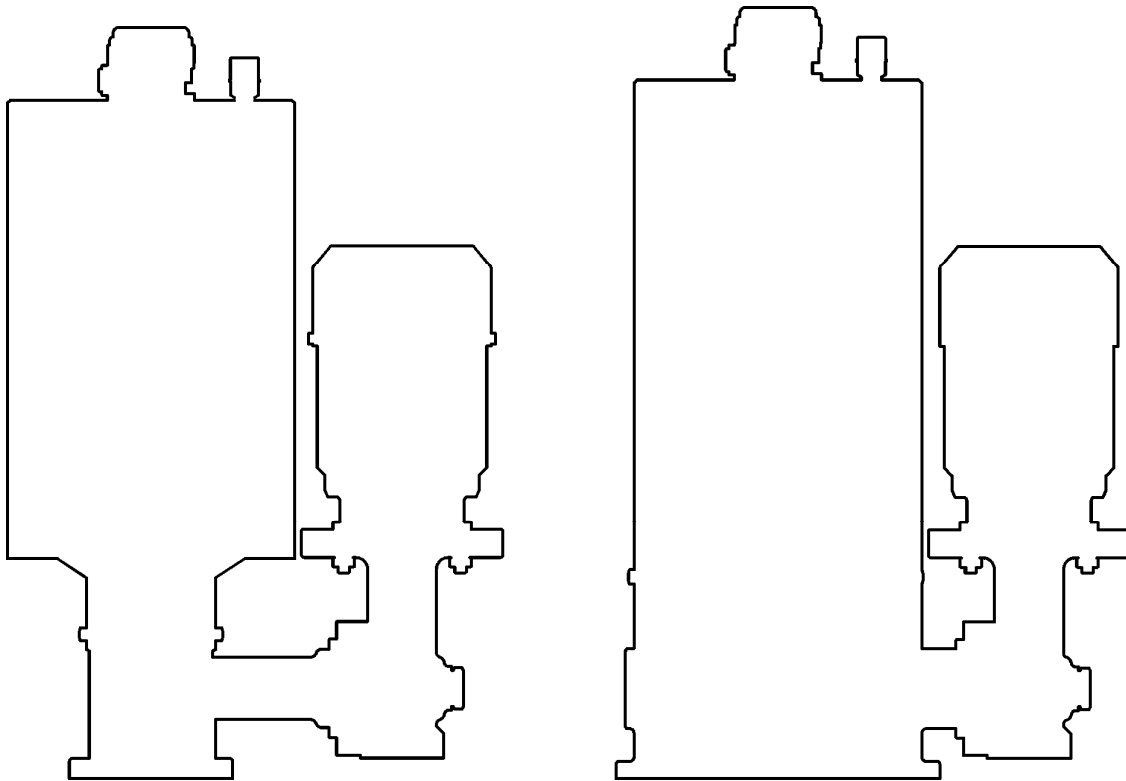

Thank you for choosing an Assalub lubricator.

It is a high-quality Swedish product. Every lubricator is subjected to comprehensive testing before delivery.

Read the instruction manual carefully to ensure correct use of the lubricator.

CONTENTS

1. Presentation
2. Safety regulations
3. Technical description
4. Assembly and installation
5. Initial start-up, setting discharge rate
6. Maintenance and repair
7. Spare parts
8. Guarantees,
9. EU Declaration

1. PRESENTATION

- ÅSSA lubricators Type FL and FE are intended for automatic grease lubrication of machinery. They can also be used for dispensing high-viscosity lubricants and lubricating pastes.
- When electrically driven lubricators (Model FLM and FEM) are to be used in an explosive environment an electric motor of the correct type and safety class must be used.

2. SAFETY REGULATIONS

- Read the instruction manual carefully before starting the lubricator.
- These lubricators may only be used for the media for which they are intended.
- All components used together with the lubricators must be capable of withstanding their flows and pressures.
- Do not exceed the maximum permissible continuous back-pressure.
- Make sure that the lubricator drive is disconnected before any dismantling or servicing.
- Note that leaks or other fine jets of liquid under high pressure can cut the skin. It is especially important to be careful with oil systems that operate under high pressure.
- Inspect the equipment for wear at regular intervals, paying particular attention to link systems in the case of ratchet drive.
- Be careful when in the neighbourhood of rotating drive shaft couplings, hand cranks and ratchet drive systems.

3. TECHNICAL DESCRIPTION

GENERAL

The two types of lubricator are of similar design and consist of:

- Top section I** – lubricant reservoir with pre-feeder
- Intermediate section II** – pump mechanism
- Bottom section III** – drive unit

MODE OF OPERATION

Type FL

When the central shaft **10** rotates, driven by shaft **17**, the pre-feeder (consisting of vane **1**, pre-feed roller **2** and angled pin **3**) feeds lubricant from the reservoir down through the strainer **4** to the cylinder pump **13** via the inlet passages **11** in the pump body **16**. The figure shows the situation when the pump cylinder is being filled with lubricant. When the central shaft continues to rotate, the pump plunger pressure ball **8** presses the pump plunger upwards when it passes the pressure ball of the respective outlet. At the same time the orifice **12** of the cylinder passage also passes one of the outlet passages **5** in the pump body and the lubricant is forced out into the line to the lubricating point via outlet **6**. The pump plunger then gets its suction movement from pin **9** when the guiding ball **15** in the central shaft engages with the setting screw **14**. Each outlet has a pressure ball **7**, a setting screw **14**, an inlet passage **11** and an outlet passage **5**. The setting screws **14** adjust the length of the pump plunger stroke and thus the lubricant discharge. The lubricant discharge rate set for each outlet is completely independent of those of the other outlets.

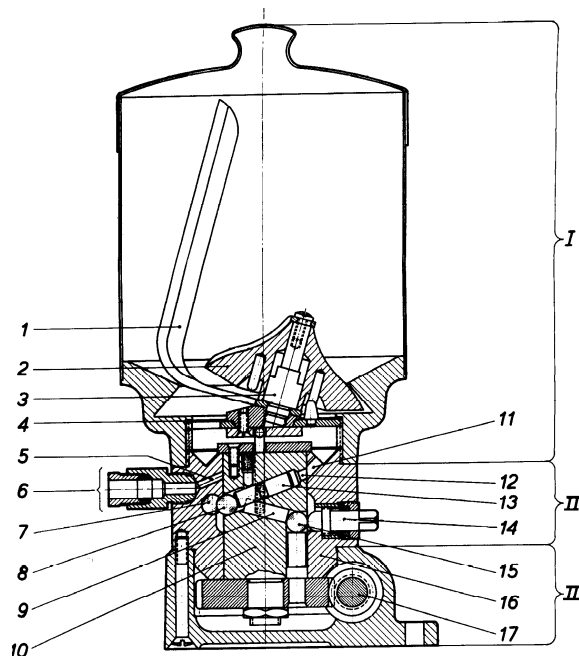

Type FE

When the central shaft **21** rotates, driven by shaft **24**, the pre-feeder **2 – 6** feeds lubricant from the reservoir through the strainer **8** to the inlet **30** of the respective pump unit **10**. At the same time, the eccentric on the central shaft and the guide plate **19** impart a plane-parallel circular motion to the pump disc **20**. By this means the pressure studs **27** give the pump plungers **28** their axial suction and pressure motion, with the rotational motion at dead centre which places the pump unit cylinder **26** alternately in communication with the intake opening **30** and the discharge connection **17** via passages **13** and **16**.

The central shaft drives the pre-feeder via the driver **9**. The pre-feeder homogenizes the grease and renders it free from air.

The discharge rate is set individually for each pump unit by adjusting the stroke of the pump plunger with the setting screw **31**. The setting screws are accessible after removal of the protective plugs **32**.

The pump units are readily accessible for replacement after removal of the top section.

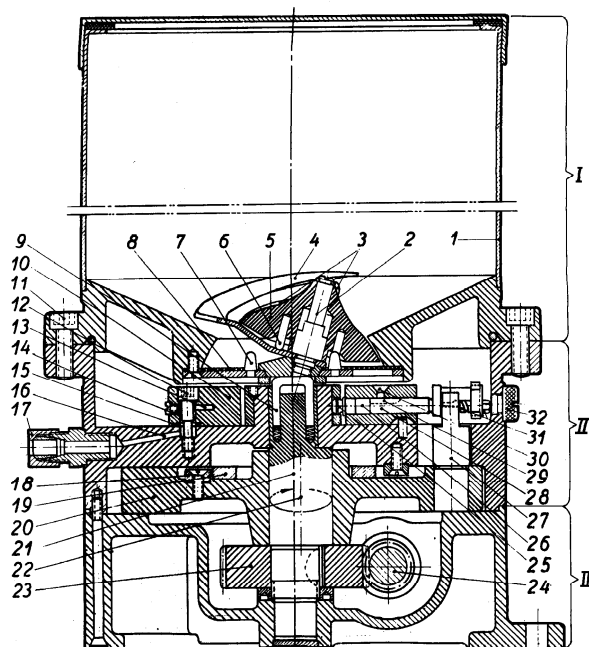

TECHNICAL DATA

Noise level

The noise level is less than 70 dB(A)

Lubricants

Lubricators of types FL and FE are capable of pumping grease with penetration up to NLGI-4. They can also be used for pumping highly viscous oils and pastes with lubricating properties. Grease with a stringy or fibrous consistency should not be used. Do not mix different kinds of grease or grease with oil. Different lubricants may slide on each other, which disturbs the pre-feed. More than 90% of all operating problems are due to contaminated lubricants or central lubrication with unsuitable grease.

Performance

Type	FL	FE
Number of outlets	1 – 6	1 – 12
Max. feed per pump stroke, cm ³	0.10	0.25
Max. continuous back-pressure, MPa	5.0	25.0
Max. intermittent back-pressure, MPa	10.0	45.0

Type/model	FLP	FLR	FLM	FEM
Ratchet lever stroke	6 – 60°	—	—	—
Max. ratchet pulses/min	450	—	—	—
Max. drive shaft rpm	—	450	—	—
Discharge/outlet and min	0.25 – 10	0.25 – 10	0.7 1.4 2.8	5.6 (50 Hz)

4. ASSEMBLY AND INSTALLATION

- Make sure when unpacking that no items are missing from the delivery.
- Before assembling, make sure that all pipes and hoses are clean inside.
- The lubricator must be installed on a level surface. Use shims to eliminate any unevenness. This is important in order to avoid stresses that might give rise to cracking. Fix the lubricator in place with three M8 bolts
- In the case of rotary drive it is advisable to connect the drive shafts together with a flexible coupling.
- With ratchet or rotary drive a guard must be fitted over moving parts in order to prevent accidents.
- Electric motors must only be connected to the mains power supply by an authorized electrician.
Note the direction of rotation of the motor as indicated by an arrow on the motor.
- Choose the diameters of piping between the lubricator and the lubrication points so as to minimize pressure drops. The following table can be used as a guide:

Pipe length	Pipe size	In choosing pipe sizes, account must be taken of:
0 – 8m	Ø8 x 1mm	-Temperature
8 – 15m	Ø10 x 1mm	-Lubricant consistency and pumpability
15 – 25m	Ø12 x 1mm	-Number of bends
> 25m	Ø15 x 1,5mm	-Number and type of connections and valves, if any.

Always use seamless cold-drawn precision steel pipes according to DIN 2391/C, Note that there must be no branches in the lubricating lines. The lubricant will always take the branch with least resistance. If it is necessary to branch the lubricating lines this must always be done by fitting a suitable progressive distributor such as ASSALUB Type PF or PFS.

5. INITIAL START-UP

- Fill the reservoir with clean lubricant of the correct grade in accordance with the maker's recommendations for the machine. See further under Lubricants.
- Fill the gear housing to the middle of the level gauge, models FLM and FEM, with gearbox oil of EP type, viscosity ISO VG 150-320.
- Screw the setting screws **14** (FL) and **31** (FE) (fig. p. 3) all the way in for maximum discharge. Run the lubricator until lubricant is discharged uniformly and without air bubbles from all outlets. Connect the lubricating lines and run the lubricator until oil emerges at the pipe orifices. Then connect the pipes to the lubrication-point connectors on the machine. Filling of the lubricating pipes can be expedited by use of a separate oil pump.
- After a time in operation, check all connections, pipes and hoses for leaks.

Setting discharge rate

The discharge rate can be reduced by screwing the setting screws counter-clockwise. On type FE the setting screw has 6 detent positions. On type FL adjustment is continuous. If the setting screw is unscrewed completely the discharge ceases. The discharge rate can be calculated and adjusted with the aid of the following table. One pump stroke corresponds to one revolution of the center shaft or the pre-feed vane in the reservoir. The pre-feed vane should always rotate clockwise, seen from above.

Discharge / pump stroke, (nominal)	Type FL	Type FE
Max.	0.10 cm ³	0.25 cm ³
One turn of setting screw =	0.03 cm ³	—
One notch of setting screw =	—	0.05 cm ³

When calculating and making settings, account must be taken of unavoidable internal leakage. This varies with the flow resistance in the piping and the back-pressure at the lubricating point and is normally about 15%. After long use the internal leakage may be somewhat larger. These lubricators work best with a setting that gives a fairly large discharge per pump stroke at a low rotational speed. For very small discharge rates we recommend that the lubricators should be driven intermittently through a separate control unit. The discharge rates can only be finely adjusted by measuring / weighing the quantity discharged at the end of the lubricating lines per unit of time.

Plugging or unplugging unused outlets

Type FL

Unused outlets can be plugged by replacing the outlet connection with plug 900153 and gasket 900742. It is important that screw 903337 with gasket F1172 should be removed; otherwise the lubricator may be damaged. The complete control unit LF317 should be replaced by plug F1167. Plugged outlets can be taken into service by replacing the plugs with the above-mentioned parts. Make sure not to forget to install screw 903337 and gasket F1172, otherwise there will be no discharge.

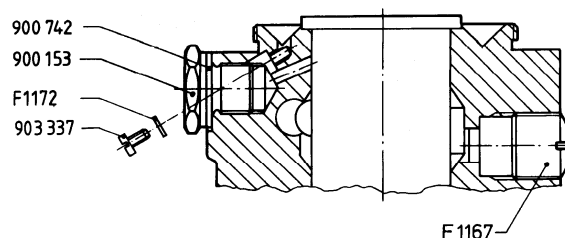

Type FE

Unused outlets must not be plugged. Any pump units that are not used must be removed and the space filled with grease. The outlet may then be plugged with plug 900153 and gasket 900742.

6. MAINTENANCE AND REPAIR

PREVENTIVE MAINTENANCE

Make regular checks of the following:

- Lubricant level in reservoir. It must not run dry.
- Oil level in drive gear for types FLM and FEM.
When necessary, top up with oil of the correct grade. The recommended oil-change interval is about 15,000 hours.

In the ratchet driven version (type FLP) the ratchet mechanism is filled with highly stable grease during manufacture. We recommend the careful introduction of a multi-purpose NLGI-2 EP grease with a grease gun through the drive ratchet housing grease nipple every 8,000 hours.

CORRECTIVE MAINTENANCE TROUBLE-SHOOTING

Problem	Action
No discharge	<p>Check that the drive is working. In the case of electrically driven lubricators, make sure that the motor is running and rotating in the direction of the arrow on the motor casing. The grease vane in the reservoir should rotate clockwise.</p> <p><u>If the grease vane does not rotate:</u> The driver F1120A or angled pin F1111 has probably broken off. Check whether any of the lubricating lines is clogged or if there is a foreign body in the reservoir.</p> <p><u>If the grease vane rotates:</u> Pump mechanism worn out or broken. On type FL replace the pump body LF338-2. On type FE replace the defective pump units LF336. Screw plug 903337 with gasket F1172 is not fitted in an outlet which is in use on type FL. See Plugging or unplugging unused outlets, chapter 5.</p>
Discharge rate too low	<p>May be due to increased internal leakage or worn pump mechanism. Increase discharge rate by screwing in the setting screws completely. If this does not help, replace pump body (FL) or pump unit (FE).</p>

REPAIR

The procedure for disassembling and assembling these lubricators is clearly apparent from the spare parts drawings. Always observe a maximum of cleanliness.

The pump body of FL pumps can only be repaired at the factory. The plungers in FE lubricators are individually fitted to the respective pump body cylinder bores and they must therefore be reinstalled in the correct pump unit.

The ratchet cross in the ratchet mechanism of type FLP must also be reinstalled in its original position, otherwise the lubricator will not work and the ratchet mechanism is liable to damage when restarted.

Repair and servicing are handled by our local agents or directly by our factory.

7.SPARE PARTS

General

When ordering spare parts always state lubricator type and serial number as on the nameplate

Definitions

Drive side

The right-hand or left-hand side of the lubricator is defined when the nameplate is not facing you.

Direction of rotation

The direction of shafts is defined looking towards the end of the shaft.

Lubricator type FL

Drive units type FLP & FLR

Art. No.	Designation	See note	Art. No.	Designation	See note
A 209	Ratchet arm		F1901-1	Spacer washer	
B 127	Nut		F 1902	Stud	
B 1065	Ratchet drive housing		F 1904	Bearing	
B 1117	Tab washer		F 1904-2	Bearing	
C 27	Spring		F 1910	Washer	
C 1060	Key		F 2054-1	Gasket	
C 1082	Plug		F 2055-1	Pipe	
C 1399	Seal ring		F 2151	Lid, 4,8 & 16 litres	
F 19-2	Grease vane, 4, 8 & 16 l	4	J 1118	Seal ring	
F 40	Pin	4	Ö 1036	Grease nipple	
F 47	Scraper	4	LF 317	Control unit	
F 49	Pre-feed roll	2, 4	LF 338-2	Pump body	
F 66	Pin	4	LF 346	Reservoir, 2 litres	4
F 1101-3	Housing	1	LF 346-1	Reservoir, 1.5 litres	4
F 1104	Washer	1	LF 347-1	Top section, 2 litres	
F 1106	Plate	3, 4	OE 408	Nut	
F 1107A	Pin	3, 4	TB 1494	Spring	1
F 1108	Strainer	4	100 734	Reservoir, 4 litres	4
F 1109A	Angled-pin plate	4	100 735	Reservoir, 8 litres	4
F 1110/l	Washer	4	100 736	Reservoir, 16 litres	4
F 1111	Angled pin	4	100 737	Lid, 4,8 & 16 litres	4
F 1113B	Lid, 2 litres	4	100 739	Top section, 4 litres	
F 1118	Ball	1	100 740	Top section, 8 litres	
F 1119A	Pin	1	100 741	Top section, 16 litres	
F 1120A	Driver		120 165	Ratchet roller	
F 1121-1	Grease vane, 2 litres	4	120 166	Wear plug	
F 1142/l	Pump shaft	1	120 170	Ratchet cross	
F 1153	Locking ring	4	120 171	Bushing	
F 1154A	Setting screw		120 172	Ratchet cross washer	
F 1155A	Setting sleeve		900 153	Plug	4
F 1156	Washer		900 194	Filter	
F 1158-1	Pressure ring		900 557	Ratchet roller spring	
F 1172	Gasket		900 558	Spring ring	
F 1215	Gasket		900 742	Gasket	4
F 1216	Pin	1	903 337	Screw	4
F 1218/l	Plunger	1	903 348	Screw	4
F 1219-2	Pin		903 383	Screw	1, 4
F 1220-2	Base (not for type FLM)		903 665	Nut	
F 1230	Hand crank		903 753	Washer	
F 1899-2	Counter ratchet housing		904 732	Screw	
F 1901	Space washer		904 738	O-ring	

Note 1 All articles with Note 1 are supplied only together as one unit, Art. No. LF 338-2

Note 2 This part is supplied only together with pin F 40 as one unit, F 49-R.

Note 3 This article is supplied only together with pin F 1107A as one unit, Art. No. F 1106-R.

Note 4 All parts with Note 4 are also included in the complete top section
 Top section 2 litres, Art. No. LF 347-1
 Top section 4 litres, Art. No. 100 739
 Top section 8 litres, Art. No. 100 740
 Top section 16 litres, Art. No. 100 741

Gear ratio	Direction of rotation		Gear A FLP FLR	Drive shaft B FLR	Drive shaft C FLP
	Drive side right	Drive side left			
2,5:1	Counter-clockwise	Clockwise	F 1226-R	F 1223	F 1229
2,5:1	Clockwise	Counter-clockwise	F 1226/l-R	F 1223/l	F 1229/l
8,2:1	Counter-clockwise	Clockwise	F 1270-R	F 1271	F 1269
8,2:1	Clockwise	Counter-clockwise	F 1270/l-R	F 1271/l	F 1269/l
22,5:1	Counter-clockwise	Clockwise	F 1225-R	F 1222	
22,5:1	Clockwise	Counter-clockwise	F 1225/l-R	F 1222/l	
45:1	Counter-clockwise	Clockwise	F 1224-R	F 1221	
45:1	Clockwise	Counter-clockwise	F 1224/l-R	F 1221/l	

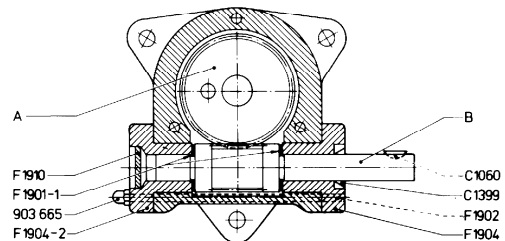
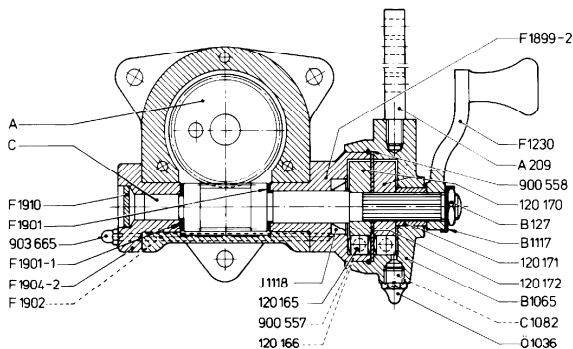
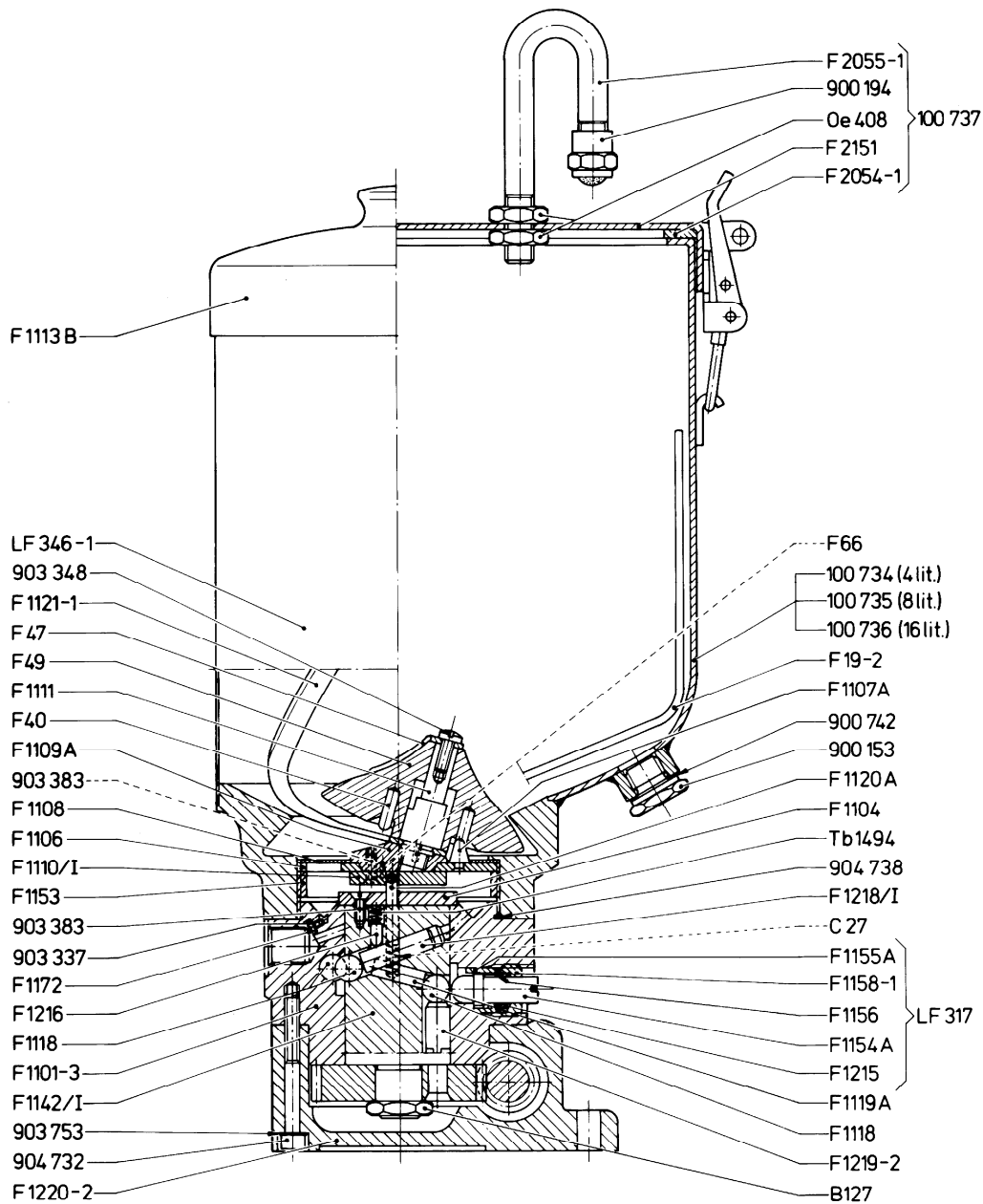

Drive unit type FLM

Complete gear without motor	Gear ratio	Drive shaft D	Gear E	Gear F	Drive shaft G
100 837	506.25:1	F 2245-3	F 1266-2	F 1225-R	F 2267-3
100 838	1012.25:1	F 2246-3	F 1267-1	F 1225-R	F 2267-3
100 839	2025.00:1	F 2246-3	F 1267-1	F 1224-R	F 2267-2

Art.no.	Designation
B 2551	Packing
B2552-1	Cover
F 1910	Disc
F 2215	Gasket
F 2233	Lock ring
F 2234	Spacer sleeve
F 2244-1	Gear housing
F 2266-1	Base
F 2269	Spacer
F 2270	Sleeve
F 2271	Washer
J 1459	Gasket
SKF KM1	Lock nut
SKF MB1	Lock washer
SKF 6200	Ball bearing
SKF 6203	Ball bearing
SV 25	Oil level gauge
900 153	Plug
900 246	O-ring
900 639	Gasket
900 742	Gasket
901 251	Motor 220 / 380 V 1400 rpm 50 Hz
901 252	Motor 220 / 380 V 2800 rpm 50 Hz
901 2XX	Motor, special execution. Please give type designation, voltage, frequency and rpm as per motor plate.
903 072	Screw
903 082	Screw
903 308	Screw
903 391	Screw
903 753	Washer
903 824	Seal ring
903 828	Circlip
903 845	Circlip
903 960	Needle bearing
904 732	Screw
904 802	Key

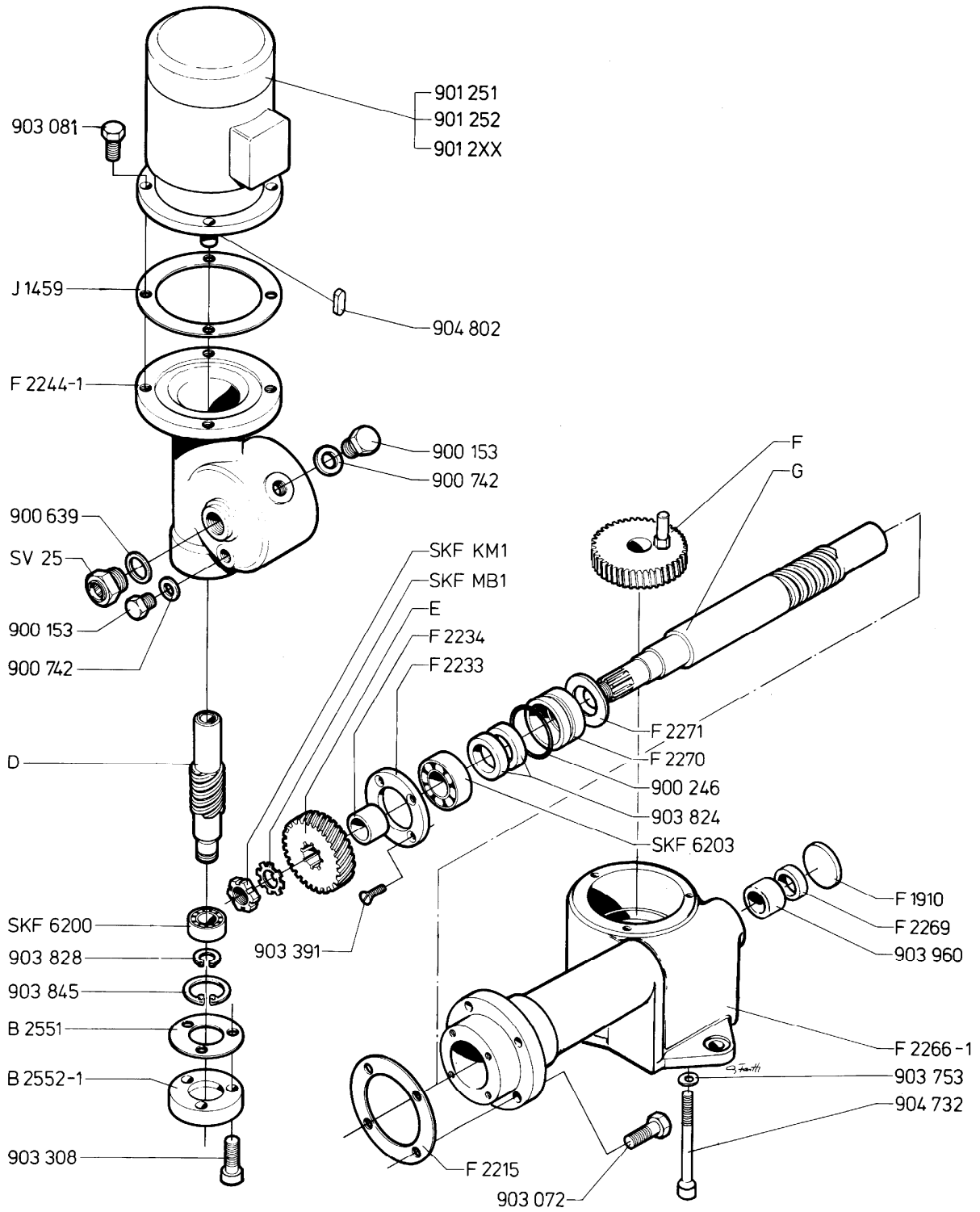

**Cover with level indicator for closed refilling
FE / FL 5 litres & FL 2 litres**

Art. No.	Designation
E1219115	Nut
F 1121-2	Grease vane
TB 2429	Spring
100 660	Cover
100 667	Switch
100 744	Cover
100 745	Sight glass
101 178	Float, complete
120 687	Plunger disc
120 692	Rod
120 755	Rod
120 757	Pin
120 758	Valve bracket
120 759	Valve disc
120 760	Cover
120 761	Bushing
120 762	Bushing
900 202	O-ring
900 825	Cable fitting
900 933	Washer
903 062	Screw
903 290	Screw
903 353	Screw
903 750	Washer
903 754	Washer
903 827	Spring clip
903 850	Spring clip
904 716	Nut
904 721	Washer
904 739	Screw
904 740	Cable fitting
904 741	Screw
904 742	Nut

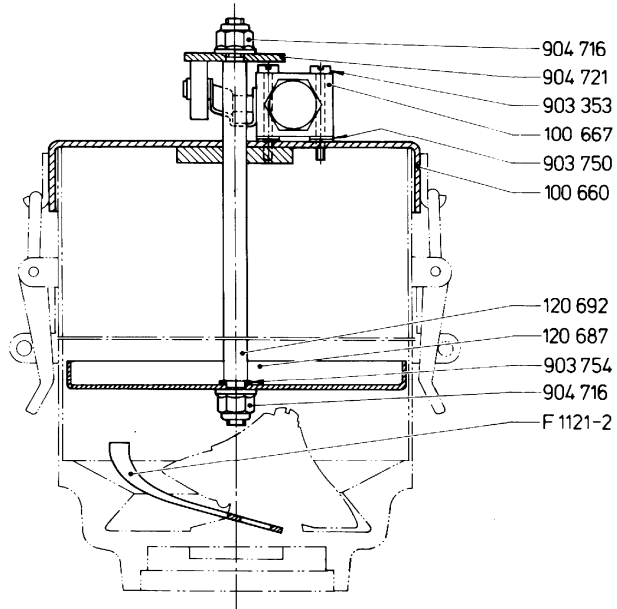
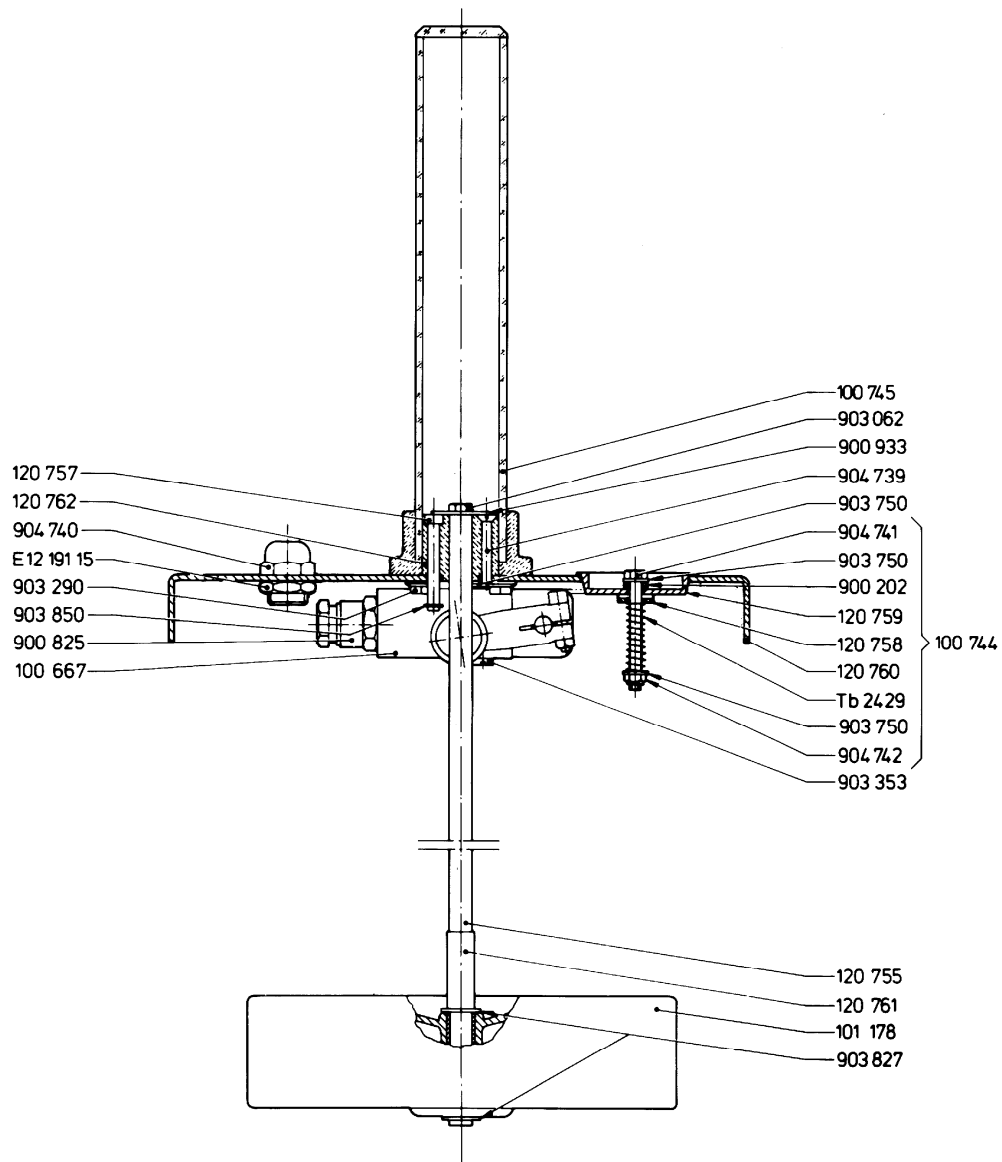

**Cover for closed refilling with high-, low- and alarm level control
FL / FE 5 and 13 litres & FE 40 litres**

Art.no.	Designation
101 047	Float, complete
120 633	Cover for level transducer (5, 13 litres)
120 634	Cover for level transducer (40 litres)
120 758	Valve bracket
120 759	Valve disc
900 194	Filter
900 248	O-ring
901 143	Level transducer (5 litres)
901 144	Level transducer (13 litres)
901 145	Level transducer (40 litres)
903 359	Screw
903 664	Nut
903 753	Washer
903 784	Washer
904 741	Screw
F 2054-1	Gasket (5,13 litres)
F 2055-1	Pipe
F 2075	Gasket (40 litres)
Oe 408	Nut
Tb 2429	Spring

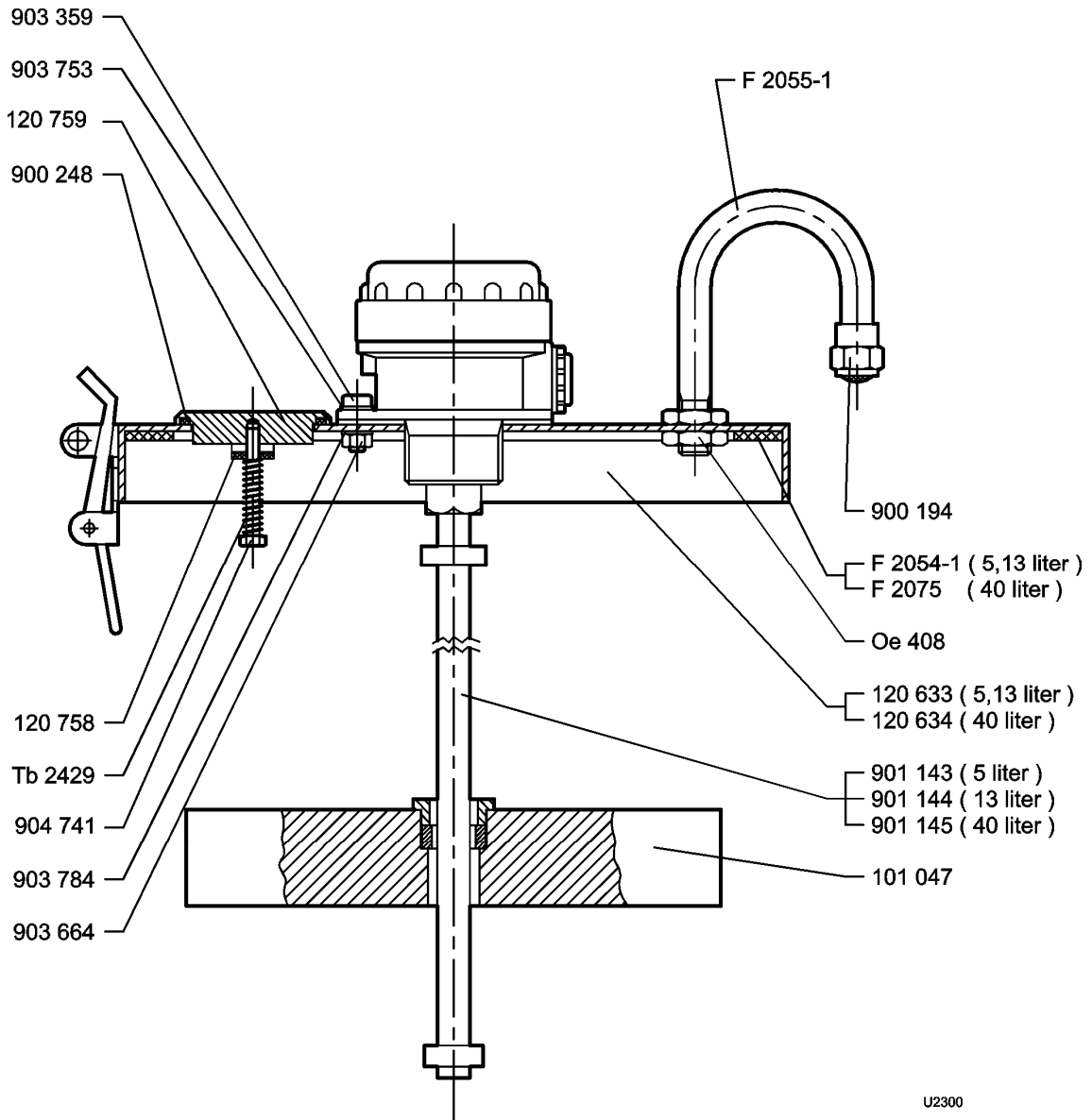

Reservoir for closed refilling FE & FL

Art.No.	Designation
F 1106-R	Bottom plate
F 1108	Strainer
F 1109A	Angled-pin plate
F 1110/I	Disc
F 1111	Angled pin
F 1153	Retaining pin
F 19-4	Grease vane
F 47	Scraper
F 49-R	Pre-feed roller
F 66	Pin
F 1700-R	Bottom plate
F 1701	Strainer
SKÖ 2356	Instruction plate
0073451	T-nipple
101 305	Safety valve
101 553	Reservoir, complete FL
101 554	Reservoir, complete FE
120 988	Follower piston
120 989	Cover
120 992	Magnet retainer
900 153	Plug
900 165	Gasket
900 742	Gasket
901 129	Air filter ½" steel
901 162	Compression spring
901 215	Level transducer
902 488	Magnet
902 881	Seal ring
902 907	O-ring
903 348	Screw
903 020	Air filter ¼" plastic
903 349	Screw
903 359	Screw
903 383	Screw
903 391	Screw
903 753	Washer
904 103	Adapter
905 208	Seal ring
905 209	Anti-friction ring

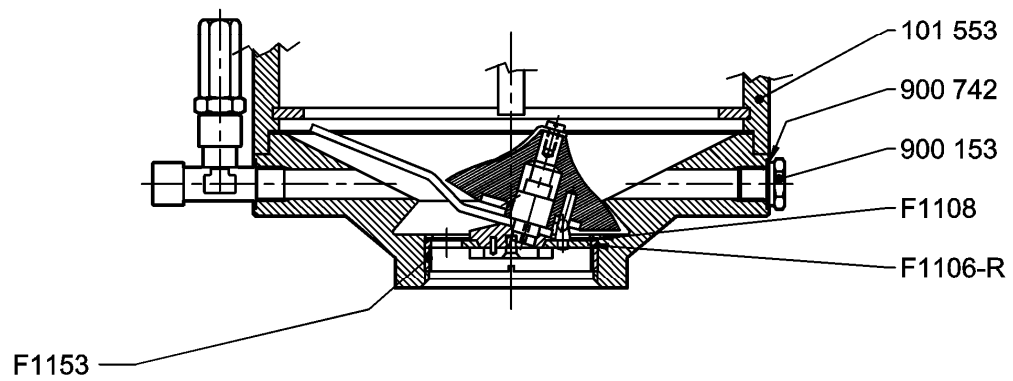
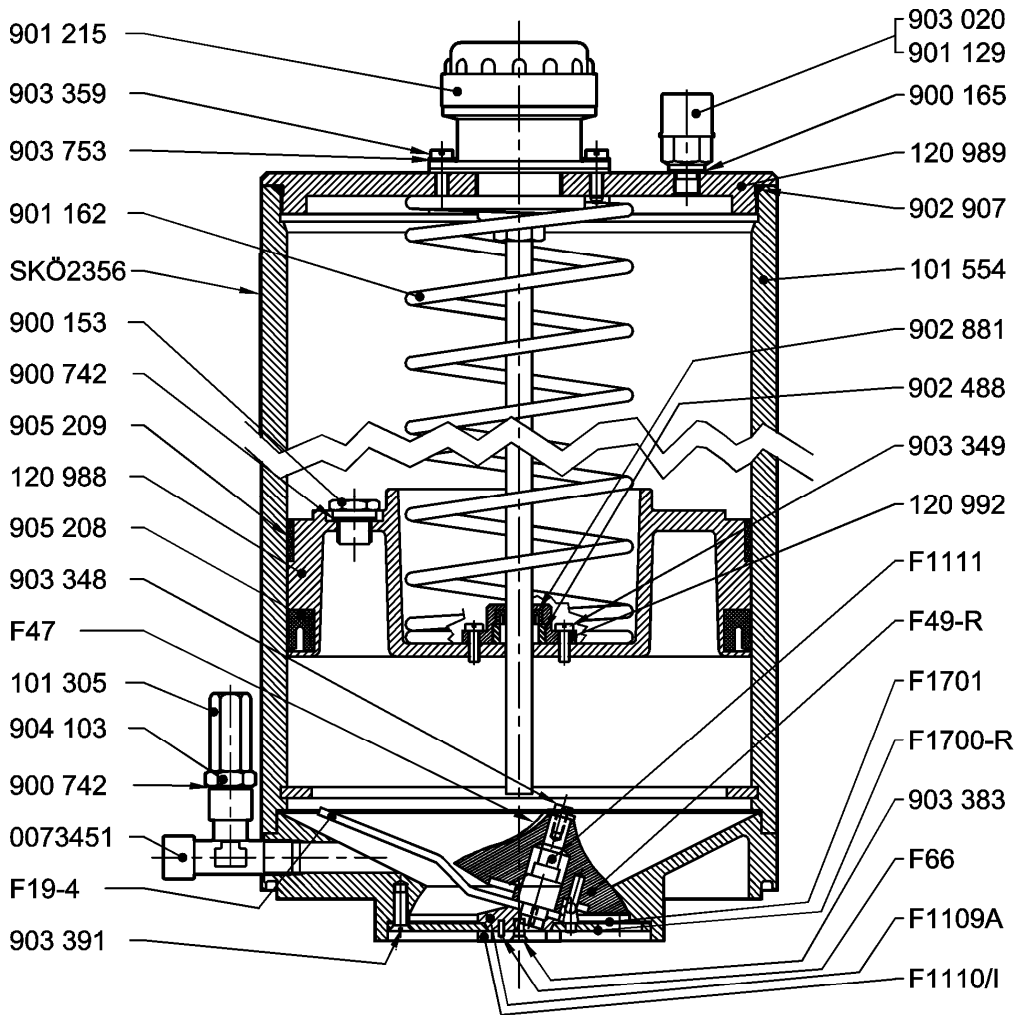

Lubricator type FEM

Art.No.	Designation	See note	Art.No.	Designation	See note
C 27	Spring		F 2231-1	Base	
B 2551	Gasket		F 2232	Drive shaft, ratio 45:1	
B 2552-1	Cover		F 2232-1	Drive shaft, ratio 22.5:1	
F 19-2	Grease vane		F 2233	Washer	
F 40	Pin		F 2234	Spacer	
F 41/I	Guide roller		F 2244-1	Housing	
F 47	Scraper		F 2245-3	Screw shaft, ratio 22.5:1	
F 49	Pre-feed roller	1	F 2246-3	Screw shaft, ratio 45:1	
F 49-R	Pre-feed roller with pin		F 2270	Sleeve	
F 66	Pin		F 2271	Washer	
F 271	Key		LF 305-1	Adjusting wrench	
F 1107A	Pin		LF 318-3	Reservoir, 46 litres	
F 1109A	Angled-pin plate		LF 321	Cover, complete, 46 litres	
F 1110/I	Washer		LF 336	Pump unit	
F 1111	Angled pin		J 1459	Gasket	
F 1120A	Driver		OE 408	Nut	
F 1266-2	Gear, ratio 22.5:1		SKF KM1	Lock nut	
F 1267-1	Gear, ratio 45:1		SKF MB1	Lock washer	
F 1533	Pin		SKF 6200	Ball bearing	
F 1700	Bottom plate	2	SKF 6203	Ball bearing	
F 1700-R	Bottom plate with pin		SV 25	Oil level gauge	
F 1701	Strainer		100 737	Cover, compl., 8 & 16 litres	
F 1722-1	Gasket		101 206	Reservoir, 8 litres	
F 1785A	Housing	3	101 207	Reservoir, 16 litres	
F 1785A-R	Housing with pins		120 815	Plug	
F 1786	Pump disc	5	900 153	Plug	
F 1788D	Pump unit	4	900 194	Filter	
F 1790A	Pump plunger	4	900 246	O-ring	
F 1791A	Setting screw		900 639	Gasket	
F 1793	O-ring		900 742	Gasket	
F 1794	Pressure stud	5	901 251	Motor 220/380 V 1400 rpm 50 Hz	
F 1795	Guide plate		901 252	Motor 220/380 V 2800 rpm 50 Hz	
F 1797	Central shaft		901 2XX	Motor, special execution Please give type, V, Hz and rpm as per motor plate	
F 1798	Ring nut		903 072	Screw	
F 1799A	Plug		903 082	Screw	
F 1803C	Gear, ratio 22.5:1		903 308	Screw	
F 1803E	Gear, ratio 45:1		903 313	Screw	
F 1857	Pin		903 321	Screw	
F 1858	Spring		903 348	Screw	
F 1870A	O-ring		903 383	Screw	
F 1910	Washer		903 391	Screw	
F 2054-1	Gasket		903 824	Seal ring	
F 2055-1	Pipe		903 828	Circlip	
F 2075	Gasket		903 845	Circlip	
F 2151	Cover, 8 & 16 litres		903 961	Needle bearing	
F 2152	Cover, 46 litres		904 780	Screw	
F 2215	Gasket		904 802	Key	

Note 1 This article is supplied only together with pin F40 as one unit, Art. No. F49-R

Note 4 This article is supplied only as complete pump unit , Art. No. LF336

Note 2 This part is supplied only together with pin F1107A as one unit, Art. No. F1700-R

Note5 This article is supplied only as complete pump disc, Art. No. 100886

Note 3 This article is supplied only together with pin F 1533 as one unit, Art. No. F 1785A-R.

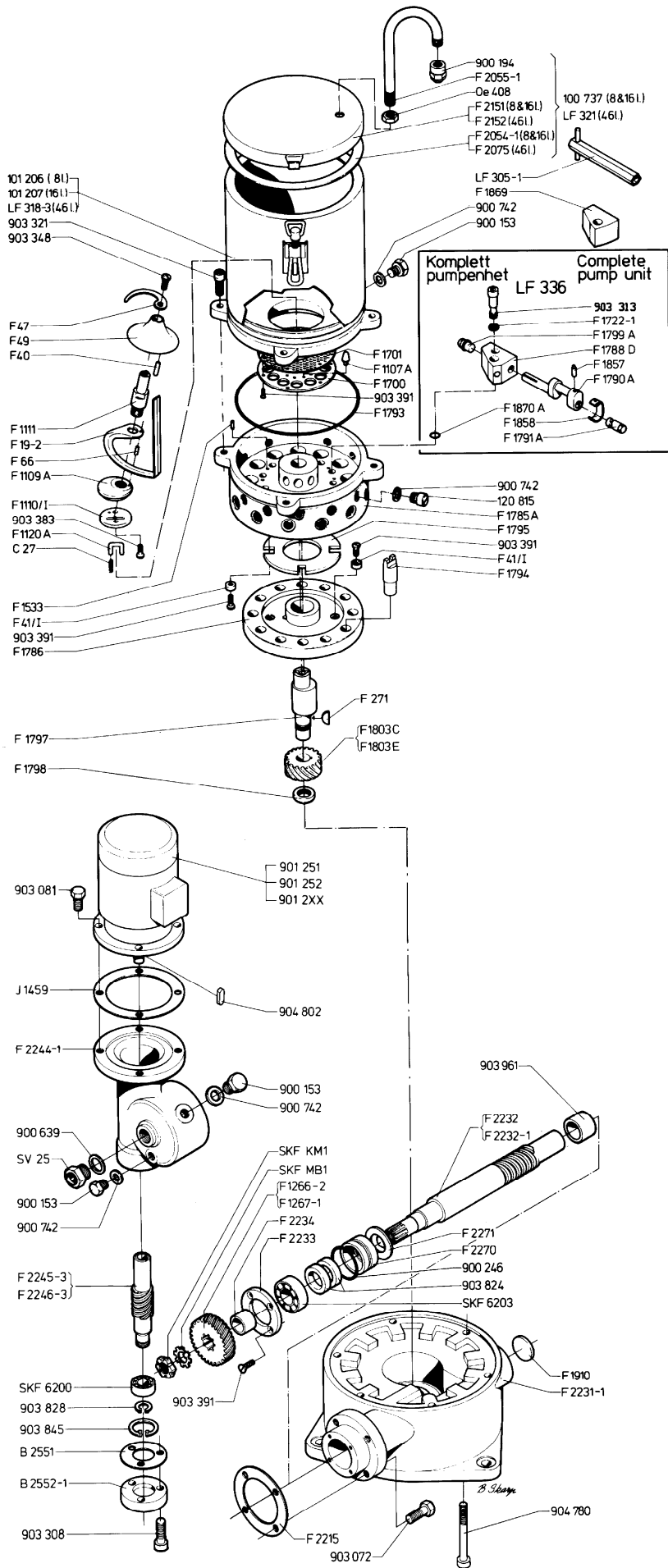

8. GUARANTEES

Correct assembly and installation in accordance with the instructions ensures safe and reliable operation.

It is important that the personnel who use the equipment carefully read the instructions in detail.

We can accept no responsibility for faults that occur due to negligence in following the instructions. The guarantee ceases to apply if the customer disassembles the lubricator without our express permission during the guarantee period.

GUARANTEE CERTIFICATE LUBRICATORS TYPE FL & FE

Delivery date: _____
Serial No.: _____
Type: _____ Order No: _____

SUPPLIED BY: _____

INSTALLED BY: _____

CUSTOMER NAME: _____

ADDRESS: _____

DATE: _____

ASSALUB AB guarantees new lubricators for 24 months from the day on which they are taken into service, but for not more than 36 months after delivery from our factory

The guarantee covers only defects that manifest themselves during correct use of the equipment and excludes defects caused by external damage, incorrect assembly, lack of maintenance or any other cause not related to material or defects in manufacture. Products in which the buyer has fitted parts of other make are excluded.

ASSALUB AB can in no case be held responsible for indirect damages or losses such as shut-downs, labour costs, lost income, penalties for delays, etc. Guarantee claims can be made for products or parts where there is clearly a defect in manufacture or material. Any faulty lubricator or component should be returned by the buyer to us or our agent for repair or replacement as we choose. All transport costs in connection with guarantee claims shall be paid by the customer. Defects due to faulty installation are the responsibility of the company which has made the installation, as stated above.

9. EU DECLARATION

EU DECLARATION OF CONFORMITY

We, Assalub AB,
Prästängsvägen 15, SE-597 30 Åtvidaberg, Sweden,
declare that the:

GREASE PUMP

Type FL and FE

is designed and manufactured in accordance with
EUROPEAN MACHINE DIRECTIVE 2006/42/EG

Åtvidaberg, December 11, 2009



Kim Funck
Managing Director



Niklas Rehn
Responsible for Technical File